

Pepe

PT2010C
Swivel Mixer

Italian made 

All dimensions in mm

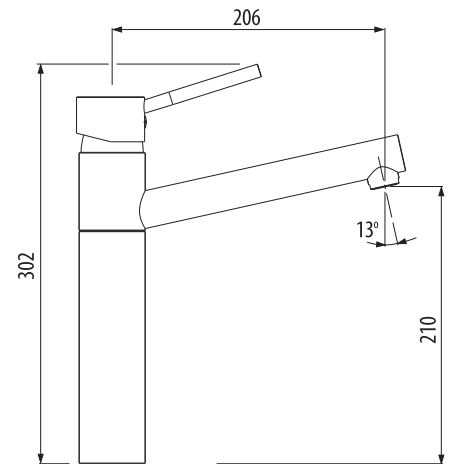

Specifications /

WELs rating	4 Stars, 7.5L per minute
Temperature rating (min / max)	1°C - 70°C
Pressure rating (min / max)	100 kPa - 600 kPa
Finish	Polished chrome
Other available finishes	Brushed chrome, matt black (powder coated) or Santorini black (powder coated)
Materials	Brass body (DR)
Cartridge size	35 mm
Cartridge type	Ceramic disc cartridge
Carton size	370 x 270 x 60 mm
Product weight	2 kg
Mixer height	302 mm
Water supply	Mains
Warranty	15 year warranty* (refer to oliveri.com.au for details)
Maintenance and care instructions	All surfaces should be cleaned with mild liquid detergent or soap and water. Do not use cream cleaners or citrus based cleaning products, as they are abrasive. Use of unsuitable cleaning agents may damage the surface. Any damage caused in this way will not be covered by warranty.

