

# True Position Drill Guide Instruction Manual

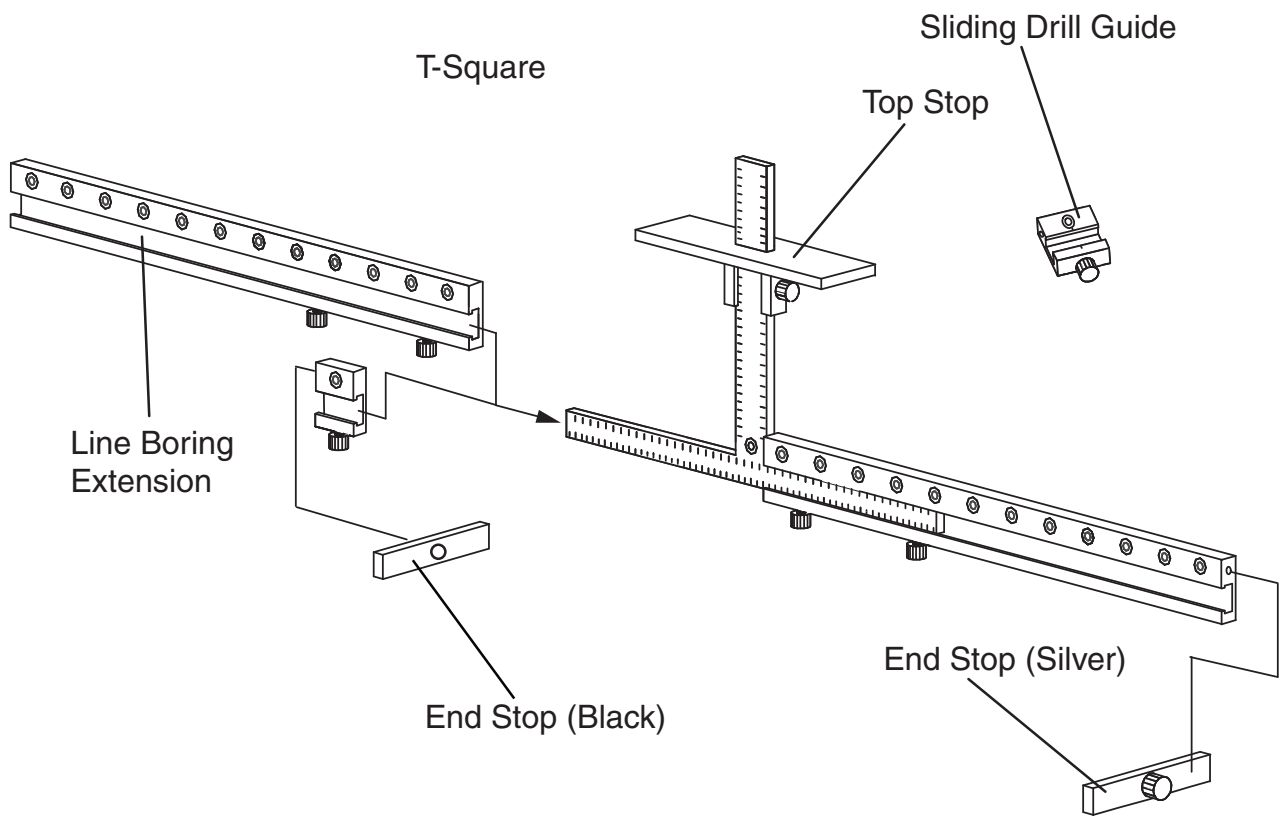

# Doors

1

Adjust handle spacing

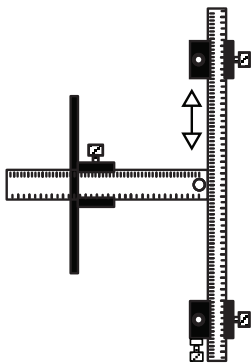

2

Adjust distance from top of door & side of door

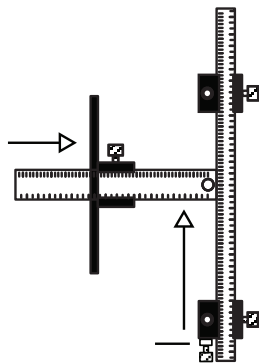

For Closer Layouts

Flip top stop upside-down to drill closer to edge

Flip sliding guide with end stop upside down to drill closer to bottom or top

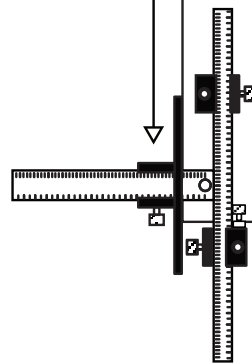

3

Set on door, hold in place while drilling

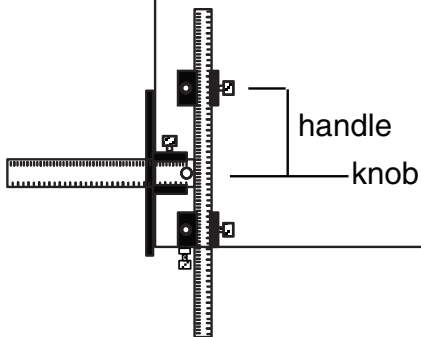

4

Opposite Door

Flip tool over on opposite door. Repeat step 3

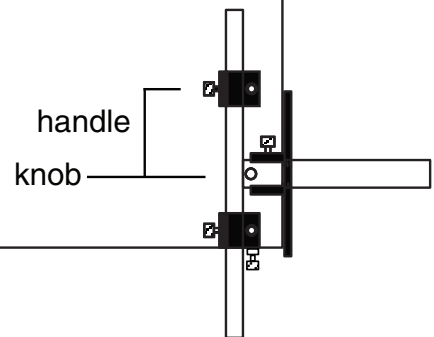

# Drawer Fronts

1

Remove end stop from sliding guide

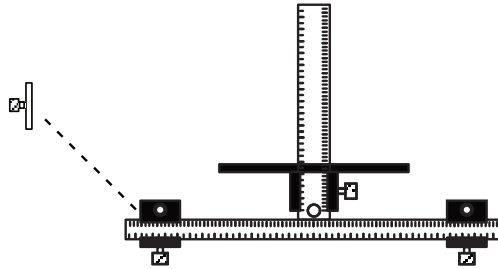

2

## Handles

Set each sliding guide at half the overall length of hardware.

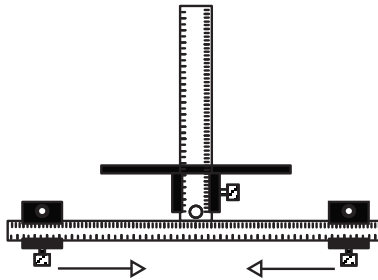

## Knobs

Leave sliding guides on for stability, t-square bushing will be used to drill.

3

Set top stop at 1/2 the distance of drawer height or desired placement.

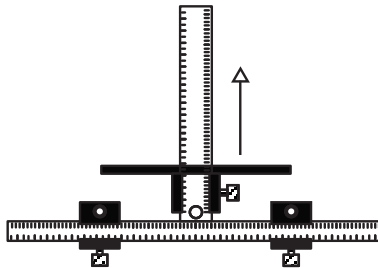

4

Draw center line on drawer front.  
Align top stop notches\* with center line.  
Hold in place & drill.

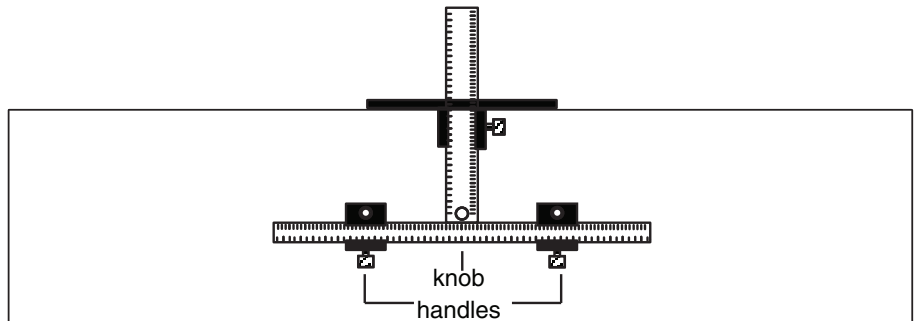

\*If tool does not have notches for center - line, notch with blade or refer to next page.



Top view

# Another Way To Do Drawer Fronts

① Remove end stop.

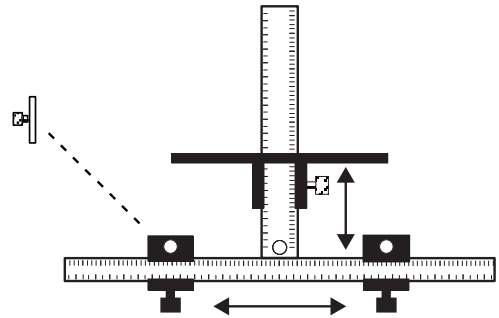

② Set up drill guide for desired spacing and height of hardware,

③ Flush end of T - square with edge of drawer front

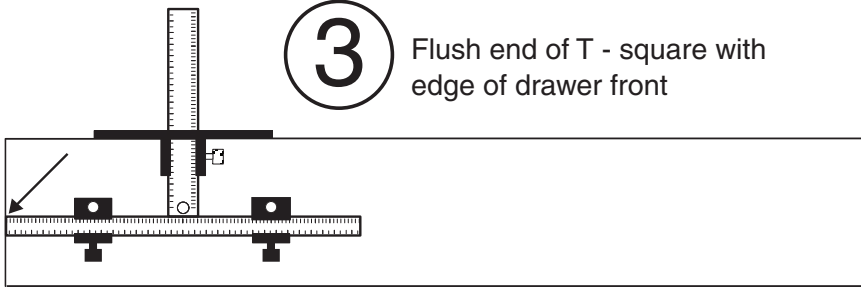

④ Measure distance from edge of t-square to end of drawer front

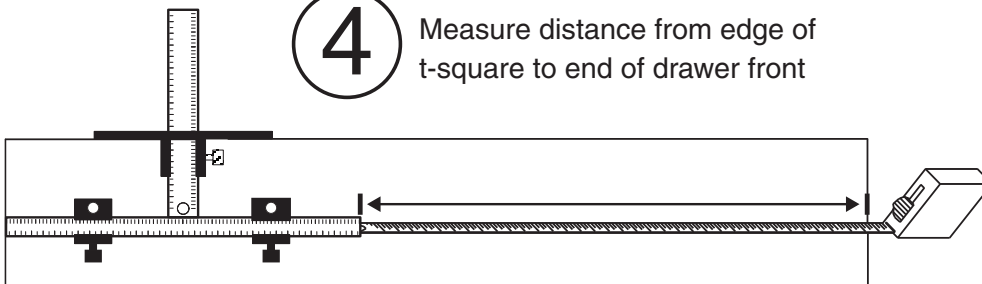

⑤ Divide distance in half while holding tape measure against tool. The tool will now be on center. Hold in place and drill

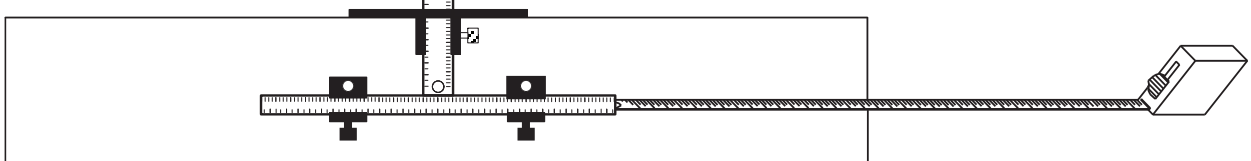

# 32mm Shelf Holes After Cabinet Assembly

## Front Holes

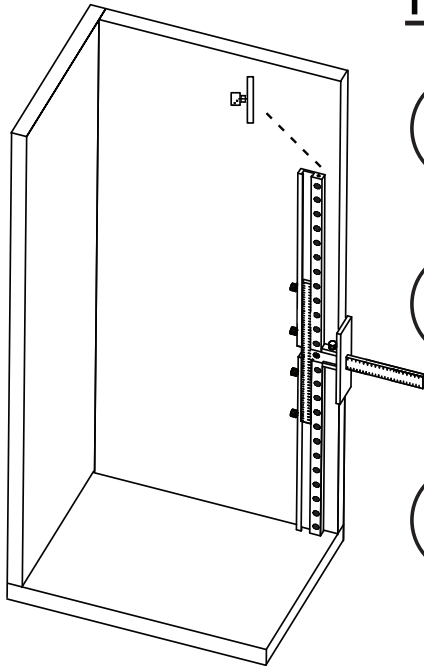

- 1** Remove End Stop
- 2** Set drill guide top stop against front of cabinet and bottom extension on bottom on cabinet.
- 3** Secure with 2 clamps - drill desired holes.

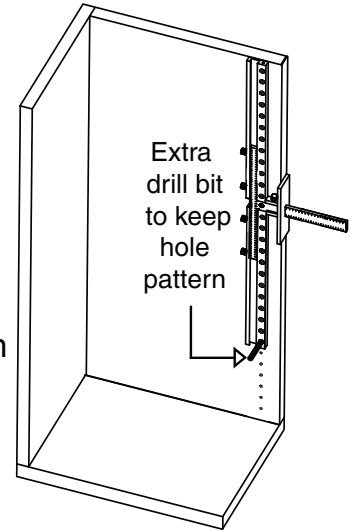

## Back Holes

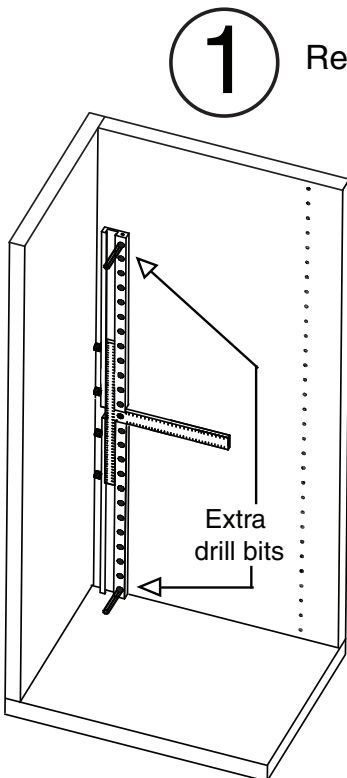

- 1** Remove Top Stop.
- 2** Place drill in back of cabinet. Press thumbscrews against the back of cabinet and the drilling extension against bottom of cabinet.
- 3** Hold against the back panel and drill first hole at the bottom, then second hole at the top.
- 4** Place extra drill bits in top and bottom holes to stabilize drill guide, drill remaining holes.

For longer panels, slide drill guide up and place drill bit in last hole drilled to maintain drilling pattern.

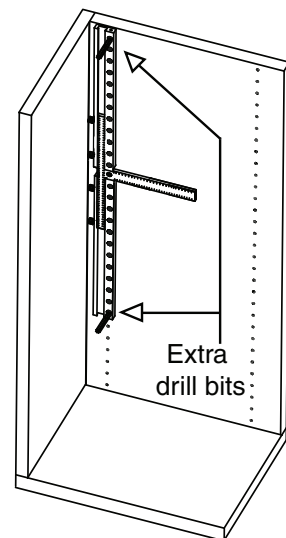

# 32mm Shelf Holes Before Cabinet Assembly

## Front Holes

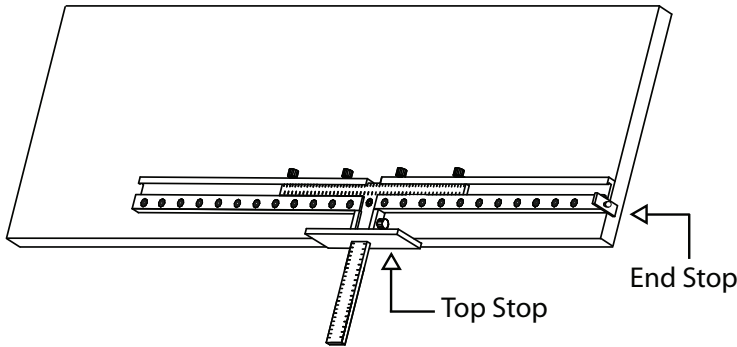

**1** Place the top stop against bottom of panel and end against edge of panel.

**2** Clamp & drill.

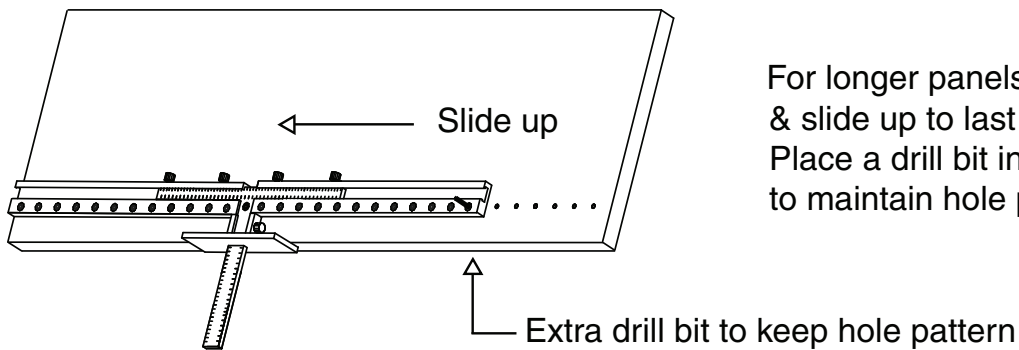

For longer panels, remove end stop & slide up to last hole drilled. Place a drill bit in last hole drilled to maintain hole pattern.

## Back Holes

**1** Flip drill guide to back of panel.

**2** Place the top stop against top of panel and extension end stop is against edge of panel.

**3** Clamp & drill.

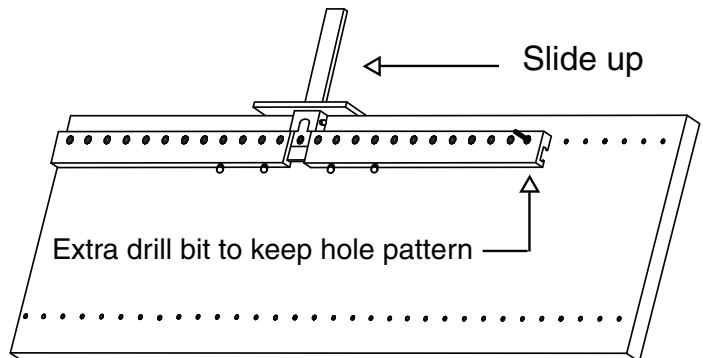
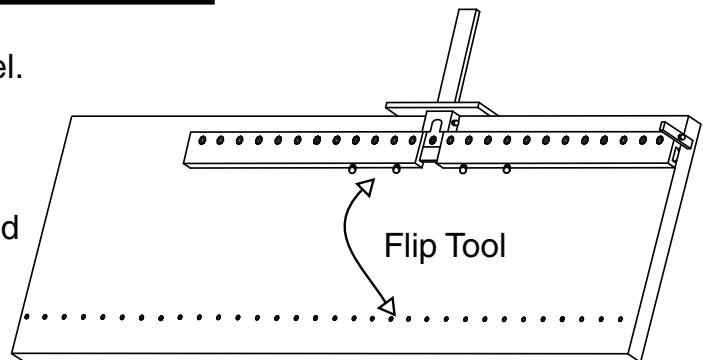

For longer panels, remove end stop & slide up to last hole drilled. Place a drill bit in last hole drilled to maintain hole pattern.

# Centering on Tall Doors

1

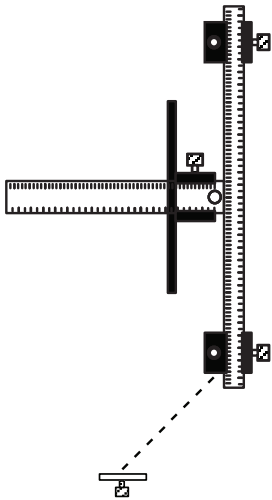

Remove end stop from sliding guide

2

Handles

Set each sliding guide at half the overall length of hardware.

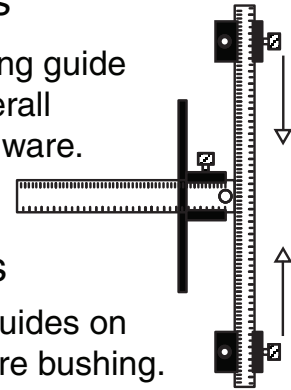

Knobs

Leave sliding guides on and use t-square bushing.

3

Set top stop at desired location from edge of door.

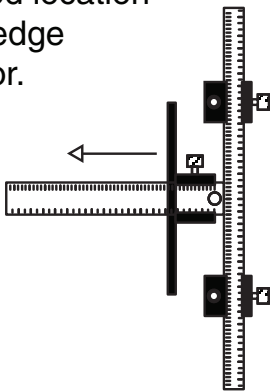

4

Draw center line on door.

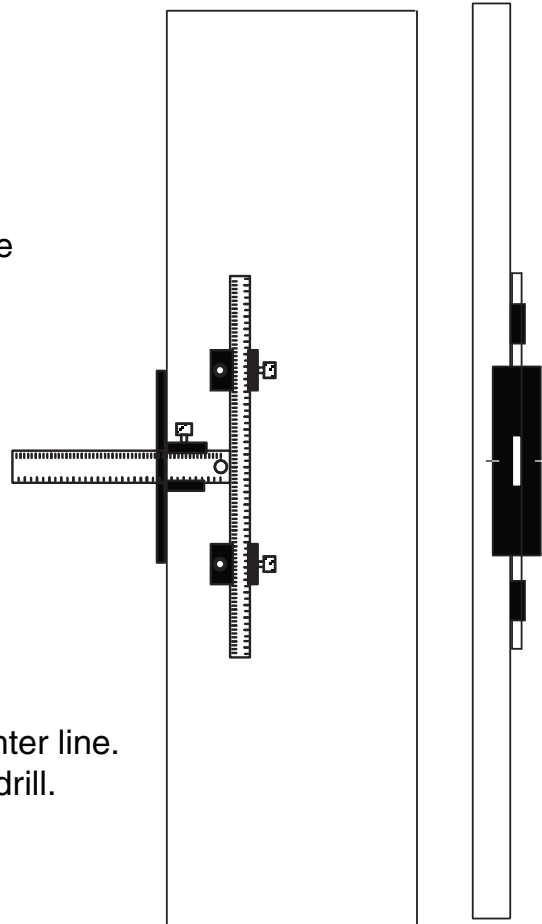

5

Align top stop notches with center line. Hold in place & drill.

Side View