

INSTALLATION INSTRUCTION

FOR SIDELINES IRONING BOARD

Step 1: Pull-out the mechanism and swivel.

Step 2: Attach to partition using 4 euro screws (D),
Top screw must be between 36 3/4"~
39 1/8" from the floor.

Step 3: Screw Ironing Board (F) to
mechanism(A) using 6
machine screws (E).

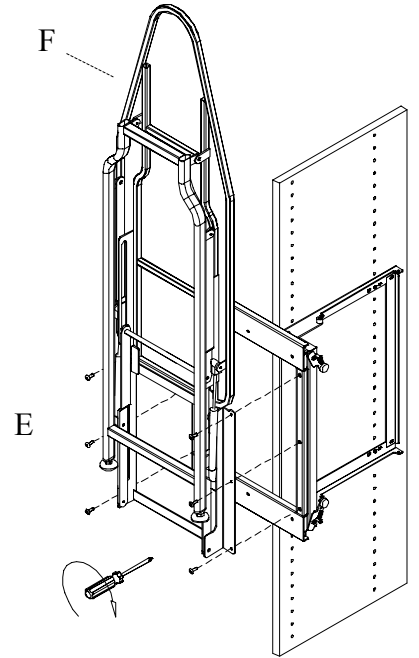
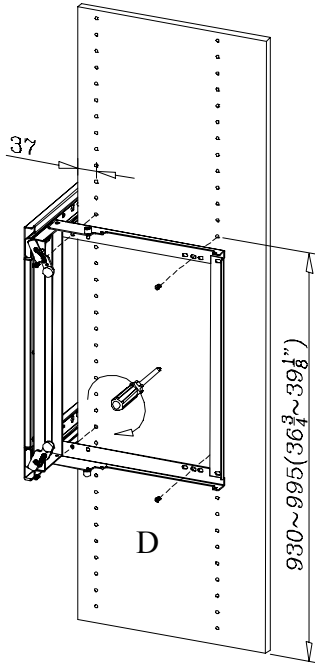
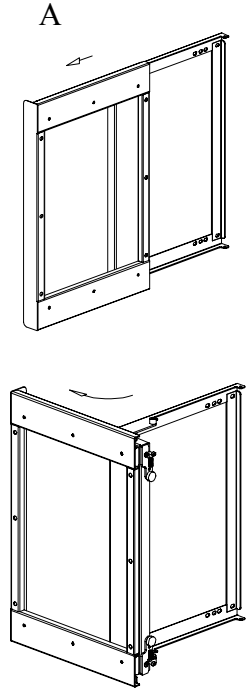



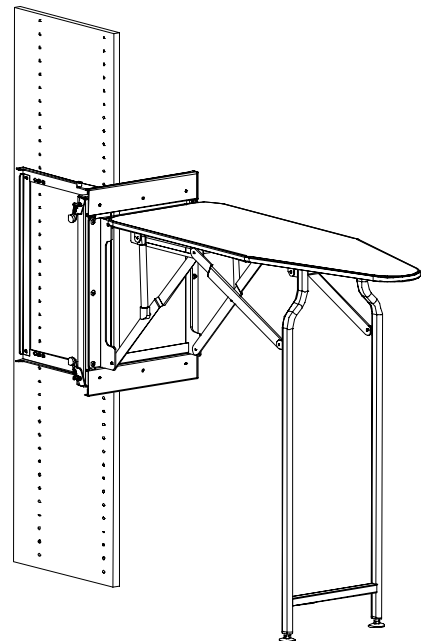
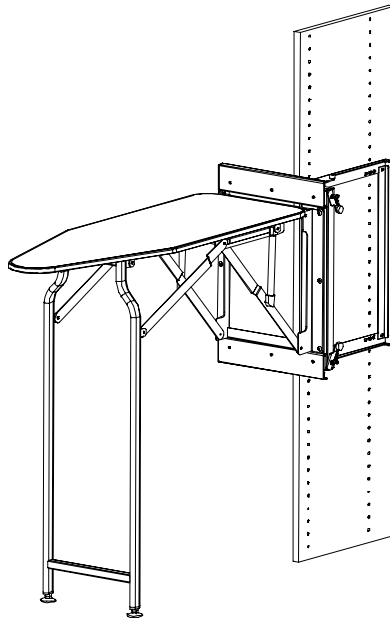
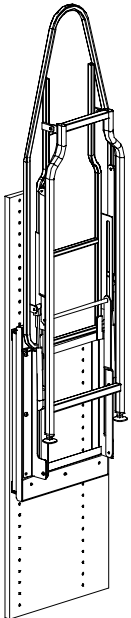

Step 4: Finished

Left

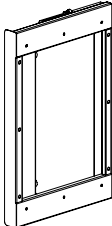
Right

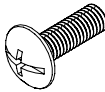

	Type	Q'ty		Type	Q'ty		Type	Q'ty		Type	Q'ty
A		1pc	D		4pcs	E		6pcs	F		1pc