

PRUA

ISTRUZIONI DI MONTAGGIO ASSEMBLY INSTRUCTIONS

MODELLO
MODEL:

1-901-040

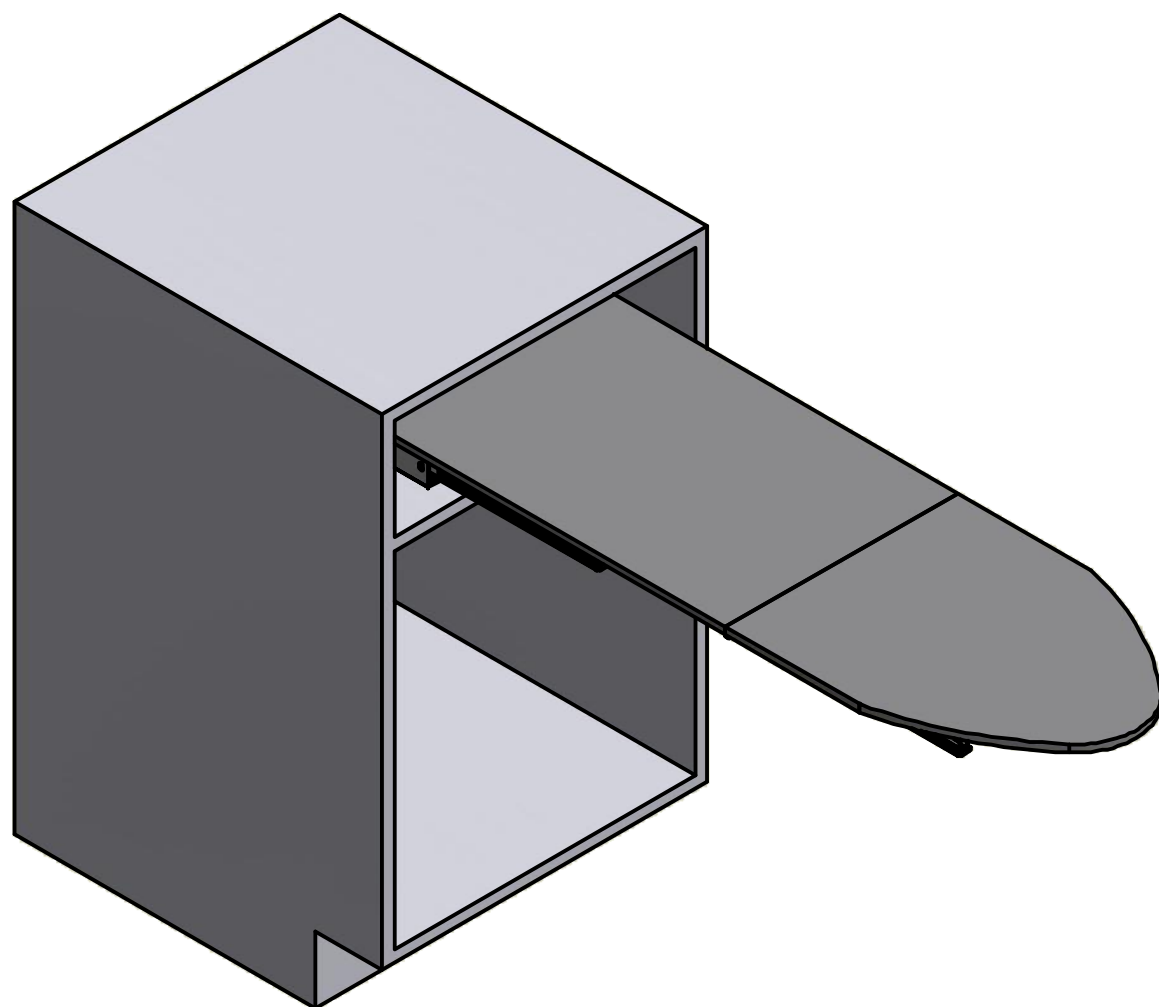



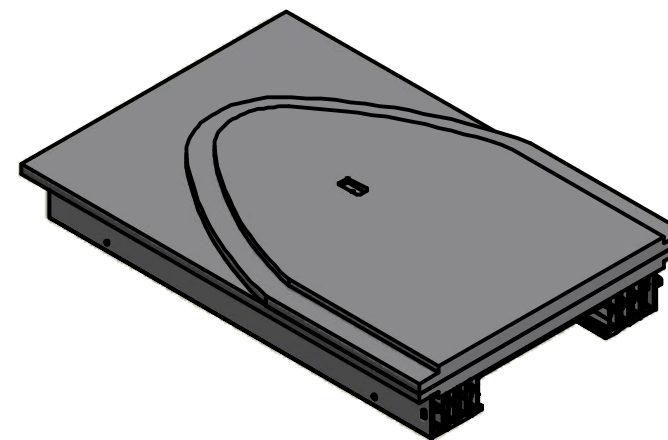

CONTENUTO DELLA CONFEZIONE INCLUDED IN THE PACKAGING

GUIDE + ASSE DA STIRO
SLIDES + IRONING BOARD



SACCHETTO ACCESSORI - ACCESSORIES

-  A. Chiave esa. da 5 - n° 5 Allen key (x 1)
-  B. Vite TCCE M6x12 - Socked head cap screws M6x12 (x 4)
-  C. Vite truciolare 3.5x20 - 3.5 x 20 Self threading screw (x1)
-  D. Clip ferma asse - Clip for plane fixing (x1)
-  E. Staffa di fissaggio - Fixing bracket (x4)

DIMENSIONI DI MASSIMA GENERAL DIMENSIONS

APERTO
OPENED

MASSIMA ESTENSIONE APERTO: 1246
MAXIMUM LENGTH OPENED

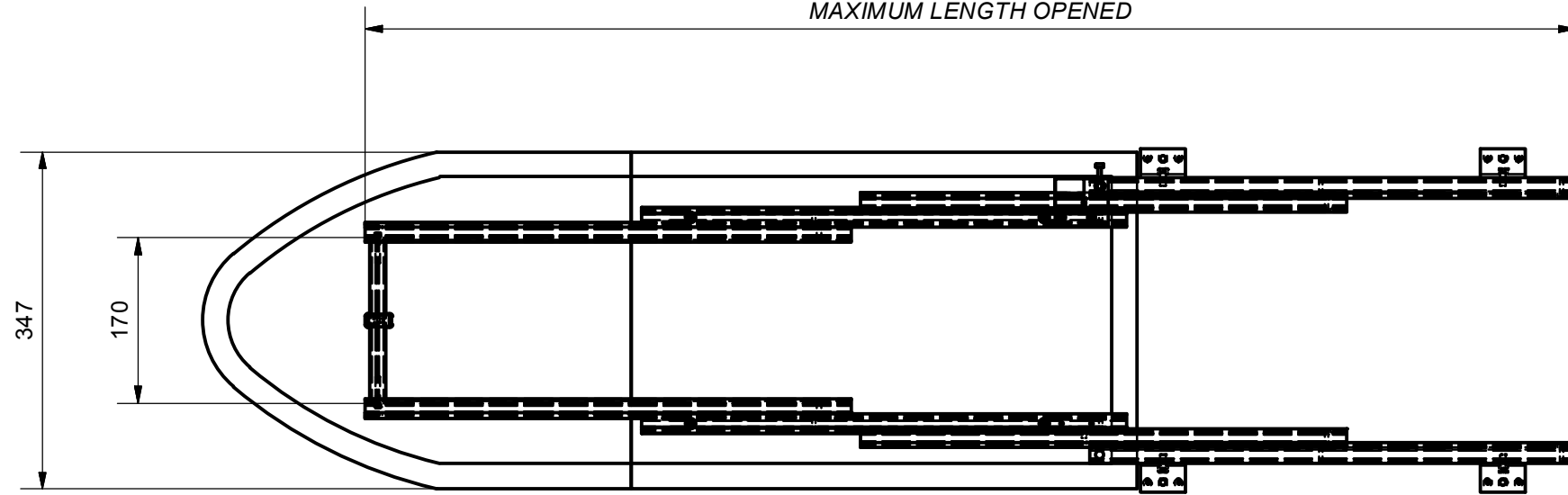

CHIUSO
CLOSED

MASSIMA ESTENSIONE CHIUSO: 520
MAXIMUM LENGTH CLOSED

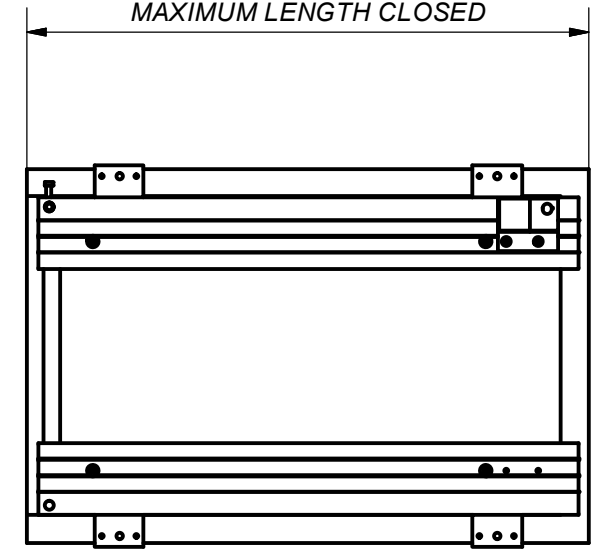

INGOMBRO IN ALTEZZA: 100
OVERALL HEIGHT

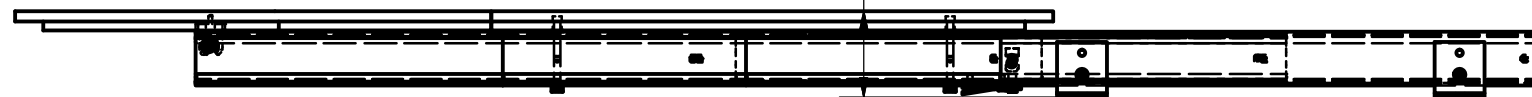

INGOMBRO IN ALTEZZA: 130
OVERALL HEIGHT

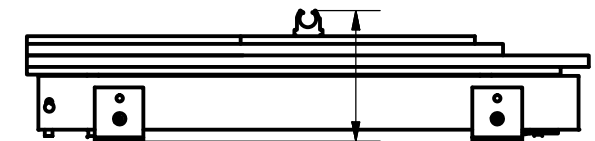

DIMENSIONI GENERALI MOBILE GENERAL CABINET DIMENSIONS

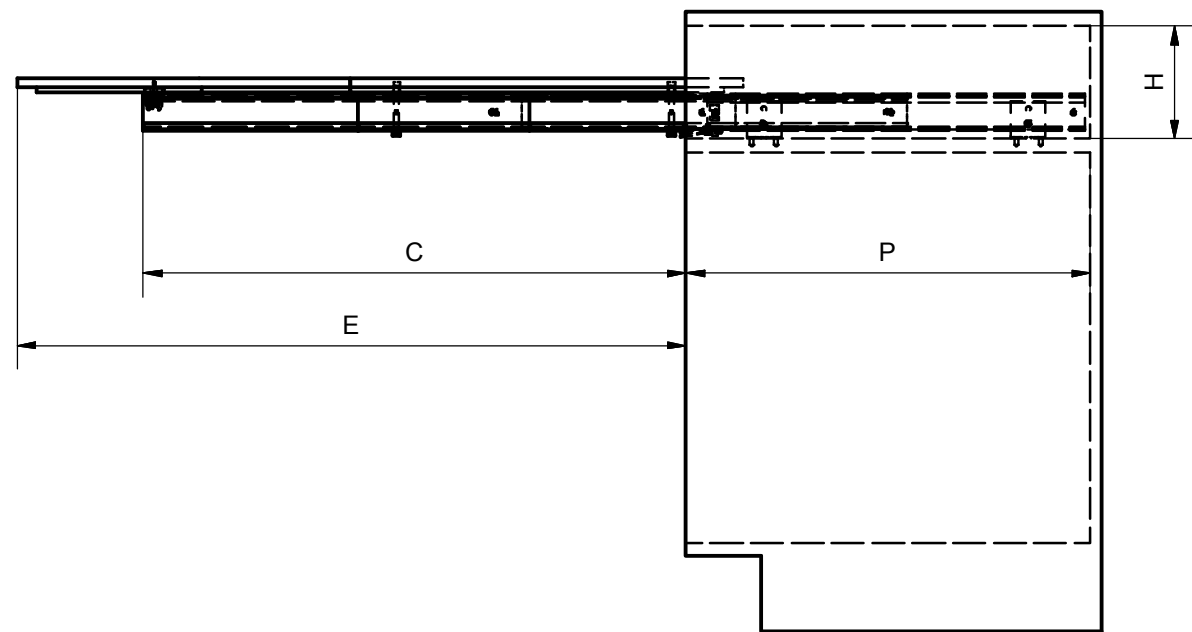

DIMENSIONE - DIMENSION	SIMBOLO - SYMBOL	mm
LUCE VERTICALE - VERTICAL SPACE	H	MIN: 150
PROFONDITA' INTERNA - INTERNAL SPACE	P	MIN: 535
LARGHEZZA PRUA - PRUA WIDTH	L1	360
LARGHEZZA PIANI - PLANES WIDTH	Z	350
APERTURA MAX PIANI - MAX OPENING PLANES	E	885
APERTURA MAX MECCANISMO - MAX OPENING MECHANISM	C	720



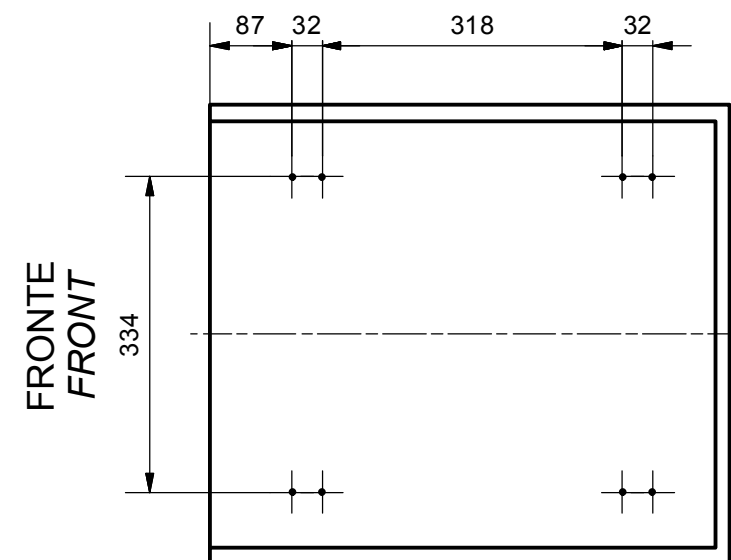
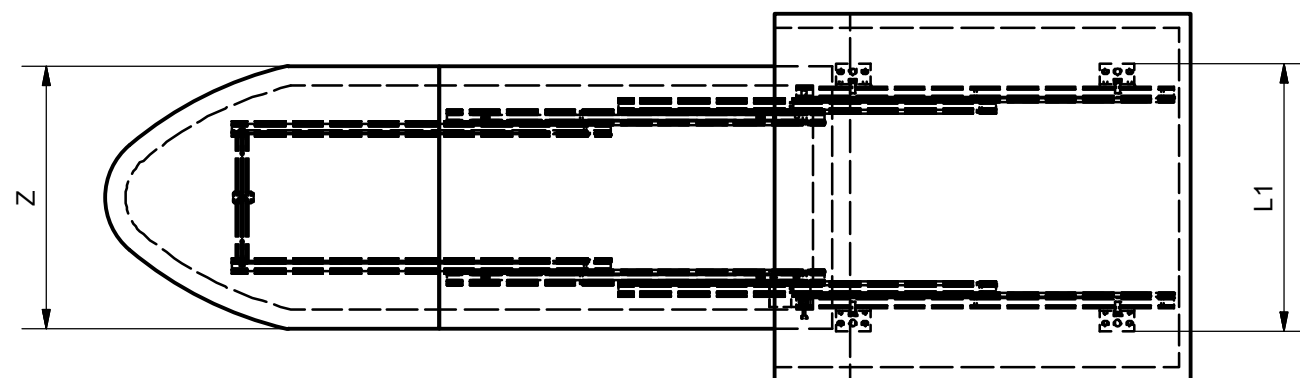

HOLES FOR MECHANISM POSITION (x8 Ø3∇10)

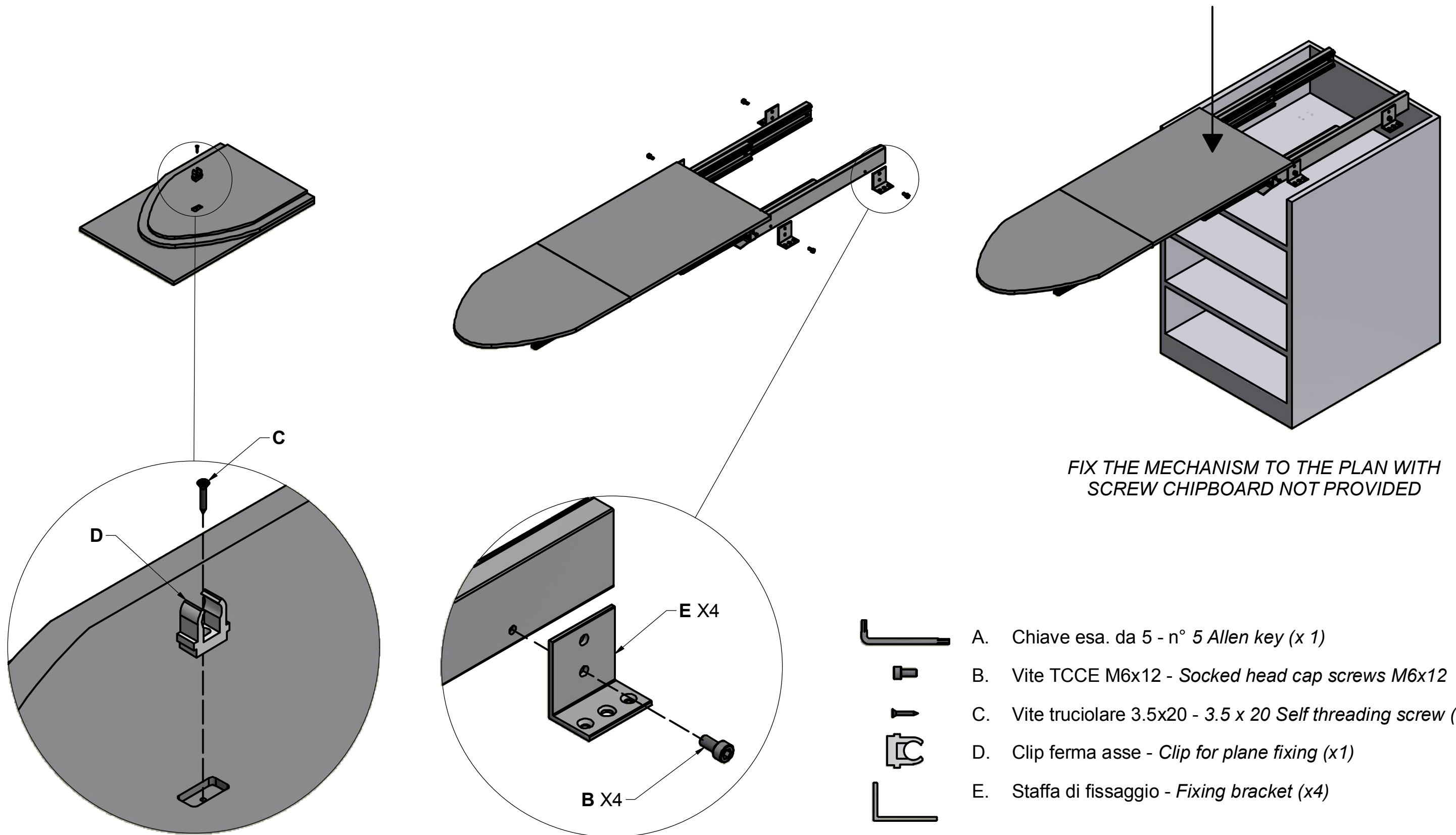

MONTAGGIO DEL MECCANISMO SUL MOBILE MOUNTING OF THE MECHANISM ON THE CABINET



FIX THE MECHANISM TO THE PLAN WITH SCREW CHIPBOARD NOT PROVIDED

-  A. Chiave esa. da 5 - n° 5 Allen key (x 1)
-  B. Vite TCCE M6x12 - Socked head cap screws M6x12 (x 4)
-  C. Vite truciolare 3.5x20 - 3.5 x 20 Self threading screw (x1)
-  D. Clip ferma asse - Clip for plane fixing (x1)
-  E. Staffa di fissaggio - Fixing bracket (x4)

SEQUENZA DI FUNZIONAMENTO FUNCTIONING STEPS

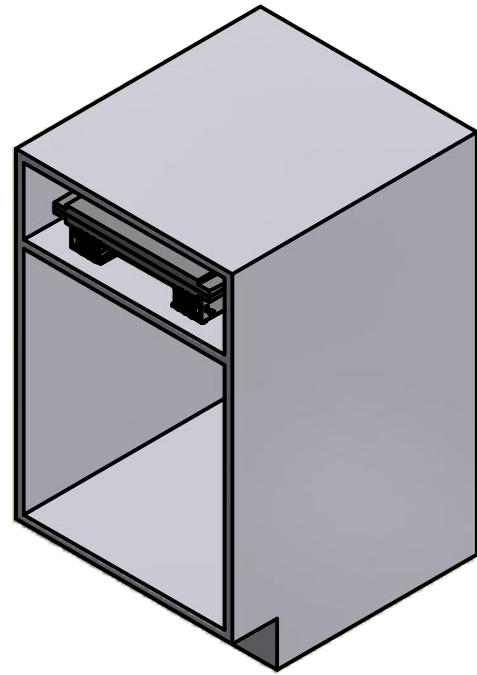

CHIUSO
CLOSED

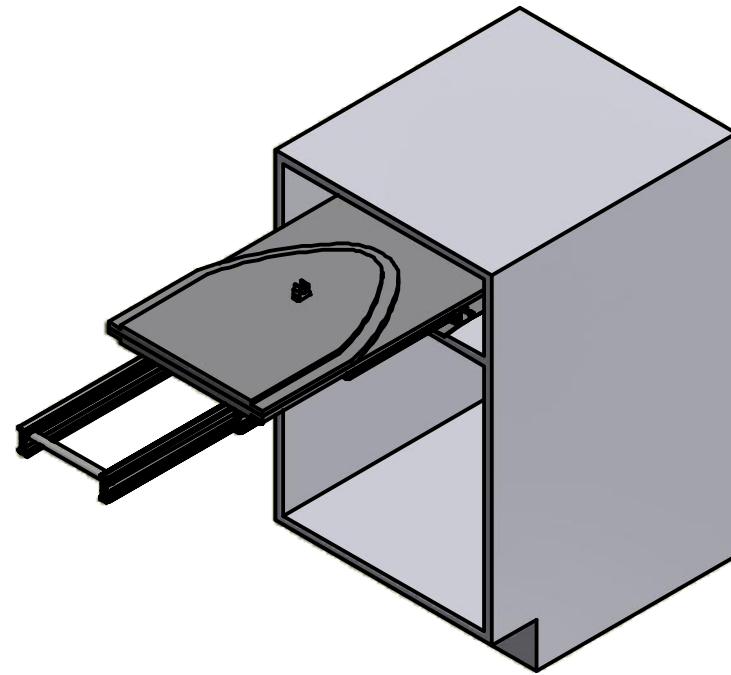

ESTRAZIONE GUIDE
SLIDES OPENING

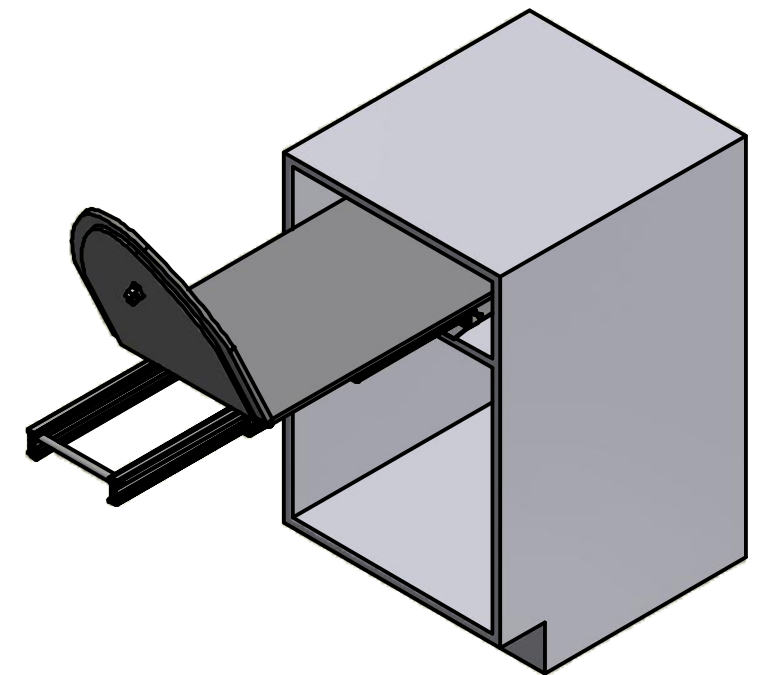

ROTAZIONE PIANETTO
PLANE TILTING

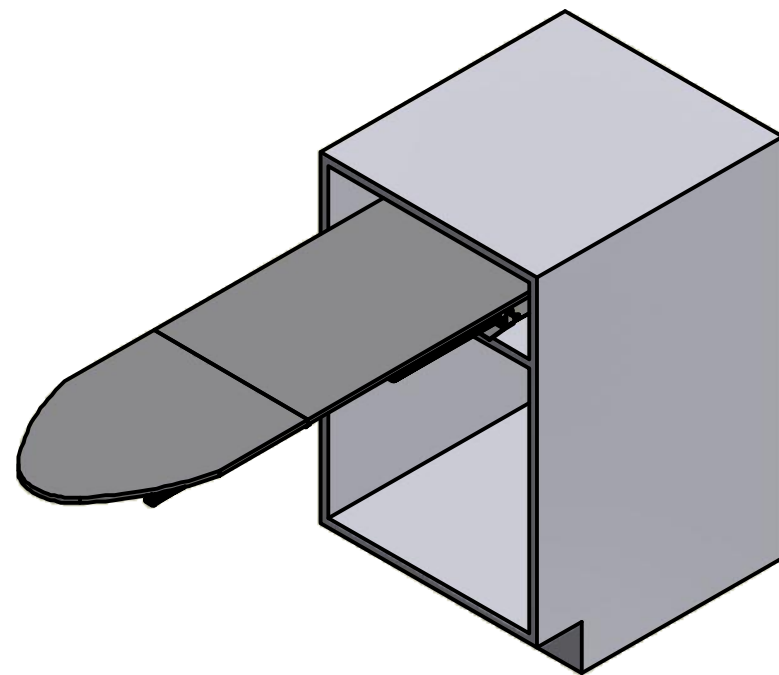

APERTO
OPENED

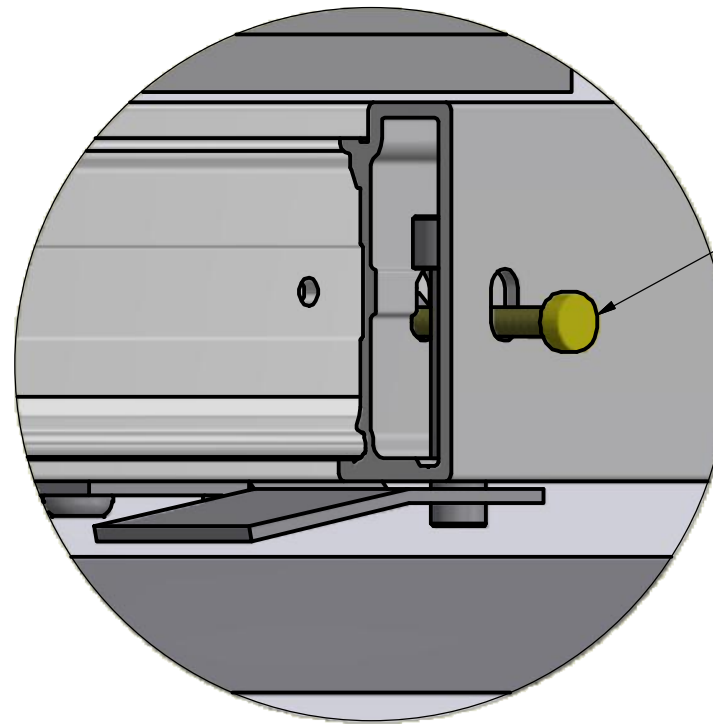

BLOCKING SYSTEM AUTOMATICALLY
ENGAGED DURING OPENING
PUSH UP THE SCREW TO CLOSE