

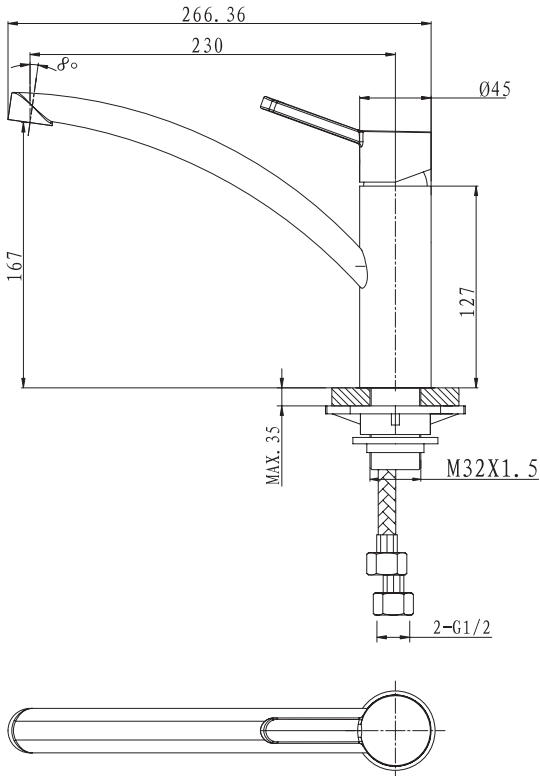



ECHO KITCHEN MIXER

Product Image	Technical Specification
	

Description	Additional Information
<p>Echo Kitchen Mixer WELS 4 Star / 7.5Lpm</p> <p>KM422621</p>	<ul style="list-style-type: none"> • 15 Year Replacement Warranty* • 35mm European Ceramic Cartridge • Quality PEX Connection Hoses • Superior Flow Regulator <div style="display: flex; justify-content: space-around; align-items: center;">   </div>

National Customer Service:
Ph: 1300 551 919
Fax: 1300 739 656

www.lincolnsentry.com.au

Scan QR code to find
your nearest branch



For locations please visit
<http://www.lincolnsentry.com.au/contact-us/locations>

