

DL2 system



Contents

Preface	4
Safety instructions	5
Before installation, reinstallation or troubleshooting	5
Before start-up	5
During operation	5
Repairs	6
Manufacturer's declaration	6
Misc. on the DESKLINE® system	7
Warranty	7
Maintenance	7
Mounting guidelines for DL2 with CBD2N control box	9
Bending moment	10
Mounting guidelines CBD2N	11
Electrical connection of the DL2 system	12
Operation with SLS	14
Description of the DESKLINE® DL2 Memory System with CBD2 E/F/G	15
Mounting guidelines for DL2 system	16
Bending moment	17
Mounting guidelines CBD2 E/F/G	18
Electrical connection of the DL2 system	19
Initialisation of the DESKLINE DL2 system	21
Operation with SLS	22
Disposal of LINAK's products	23
Label	24
Drawing appendix	25
Addresses	28

Preface

We are delighted that you have chosen a product from LINAK A/S. LINAK systems are high-tech products based on many years of experience in the manufacture and development of actuators, electric control boxes, controls and chargers. We are also constantly improving our products to meet customer requirements.

This User Manual will tell you how to install, use and maintain your LINAK DESKLINE® products.

We are sure that the DESKLINE® products will give you many years of problem-free operation. Before our products leave the factory they undergo full function and quality testing. Should you nevertheless experience problems with your systems, you are always welcome to contact our service departments or service centres.

LINAK subsidiaries and distributors all over the world have authorised service centres, which are always ready to help you.

LINAK provides a warranty on all its products. This warranty, however, is subject to correct use in accordance with the specifications, maintenance being done correctly and any repairs being carried out at a service centre, which is authorised to repair LINAK products.

Changes in installation and use of LINAK systems can affect their operation and durability. Changes must therefore only be made by agreement with LINAK A/S and are made at your own risk.

LINAK A/S

Safety instructions



Failure to comply with instructions marked with the warning symbol may result in accidents involving serious personal injury.

Failure to comply with instructions marked with the “NOTE” symbol may result in serious damage to the system or one of its components.

Persons who do not have the necessary experience or knowledge of the product/products must not use the product/products. Besides, persons with reduced physical or mental abilities must not use the product/products, unless they are under surveillance or they have been thoroughly instructed in the use of the apparatus by a person who is responsible for the safety of these persons.

Moreover, children must be under surveillance to ensure that they do not play with the product.



It is important for everyone who is to connect, install or use the systems to have the necessary information and access to this User Manual.



If there is visible damage on the product it must not be installed.



The appliance is not intended for use by young children or infirm persons without supervision.



Young children should be supervised to ensure that they do not play with the appliance.

Before installation, de-installation or troubleshooting:

- Stop the DL2
- Switch off the power supply and pull out the mains plug.
- Relieve the DL2 of any loads, which may be released during the work.

Before start-up:

- Make sure that the system has been installed as instructed in this User Manual.
- Make sure that the voltage at the control box is correct before the system is connected to the mains.
- System connection. The individual parts must be connected before the control box is connected to the mains. See the User Manual for LINAK actuators, if necessary.

During operation

- If the control box makes unusual noises or smells switch off the mains voltage immediately.
- Take care that the cables are not damaged.
- Unplug the mains cable on mobile equipment before it is moved.
- The products must only be used in an environment, which corresponds to their IP protection.

Repairs

In order to avoid the risk of malfunction, all DESKLINE® repairs must only be carried out by authorised LINAK workshops or repairers, as special tools must be used and special gaskets must be fitted. Lifting units/lifting columns under warranty must also be returned to authorised LINAK workshops.



Warning!

If any of the DESKLINE products are opened, there will be a risk of subsequent malfunction.



Warning!

The DESKLINE® systems do not withstand to cutting oil.



DECLARATION OF INCORPORATION OF PARTLY COMPLETED MACHINERY

LINAK A/S

Smedevænget 8
DK - 6430 Nordborg

Name and address of the person authorized to compile the relevant technical documentation:
John Kling, Group Headquarters, Guderup, DK-6430 Nordborg, email jkl@linak.com

Herewith declares that LINAK Actuators and Actuator Systems comply with the following parts of the Machinery Directive 2006/42/EC, ANNEX I, *Essential health and safety requirements relating to the design and construction of machinery*:

1.5.1 Electricity supply: *Directive 2006/95/EC on the harmonization of the laws of Member States relating to electrical equipment designed for use within certain voltage limits.*

1.5.10 Radiation, 1.5.11 External radiation: *Directive 2004/108/EC on the approximation of the laws of the Member States relating to electromagnetic compatibility.*

The relevant technical documentation is compiled in accordance with part B of Annex VII and that this documentation or part hereof will be transmitted by post or electronically to a reasoned request by the national authorities.

This partly completed machinery must not be put into service until the final machinery into which it is to be incorporated has been declared in conformity with the provisions of this Directive, where appropriate.

Date: 2010-01-01

Signature:

John Kling
Certification and Regulatory Affairs

Misc. on the DESKLINE® system

Warranty

There is a 36 months' warranty on the DESKLINE products against manufacturing faults from the production date of the individual products (see label).

LINAK A/S' warranty is only valid in so far as the equipment has been used and maintained correctly and has not been tampered with. Furthermore, the system must not be exposed to violent treatment. In the event of this, the warranty will be ineffective/invalid. For further details, please see LINAK A/S ordinary conditions of sale.

Maintenance

Clean dust and dirt on the outside of the system, at appropriate intervals and inspect them for damage and breaks.

Inspect the connections, cables and plugs and check for correct functioning as well as fixing points.



The cleaners and disinfectants must not be highly alkaline or acidic (pH value 6-8).

The DESKLINE® DL2 system contains following products:

- 1 or 2 DL2 lifting column(s) (no memory or parallel drive)
- 1 Control box CBD2
- 1 DP (Desk Panel)
- 1 Exchangeable mains cable
(With mains cut-off the cable is not exchangeable)

Options:

- Built-in control box (CBD)
- Class 1 protection (not if built-in CBD)
- Prepared for 1 or 2 anti-squeeze safety switches
(NO type = normally open), only stop (not if built-in CBD)

Mounting guidelines for DL2 with CBD2N control box

The DL2 column is supplied with either 8 mm end plates or 3 mm end plates.

8 mm end plates:

For mounting on the desk frame there are 4 holes for M10 bolts. It is recommended to use all 4 bolts.

3 mm end plates:

For mounting on the desk frame there are 4 holes in the column for DG 80 x 35 screws. It is recommended to use all 4 screws.

As the table top amplifies the sound we advise you to place a vibration/shock-absorbing material between the table top and the table frame.

The outer profile of the DL2 column has tracks, which can be used for mounting a bracket. The mounting bracket can be used for e.g.:

- Mounting a customised cover (for encapsulation of the DL2).
- Mounting of a computer

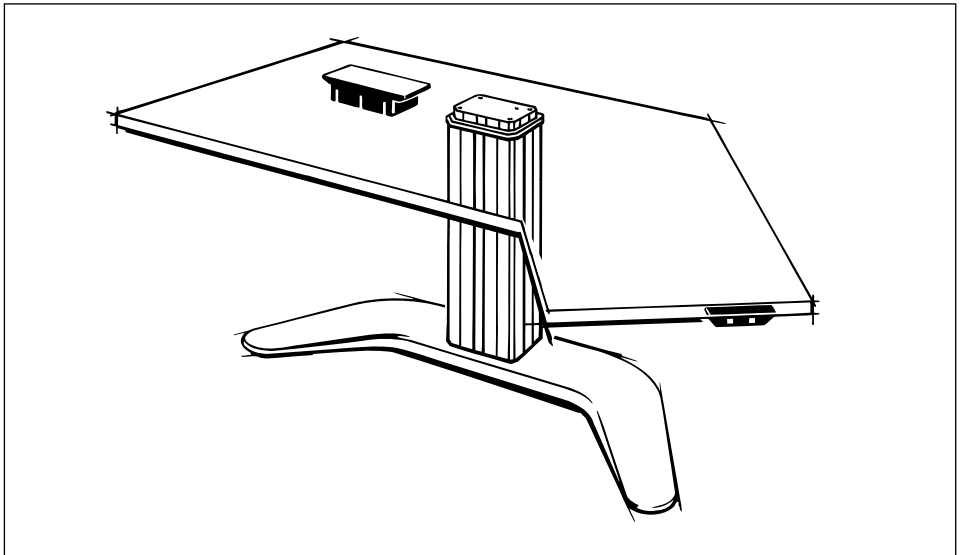

Figure 1
Example of how to mount a DL2 system

Bending moment

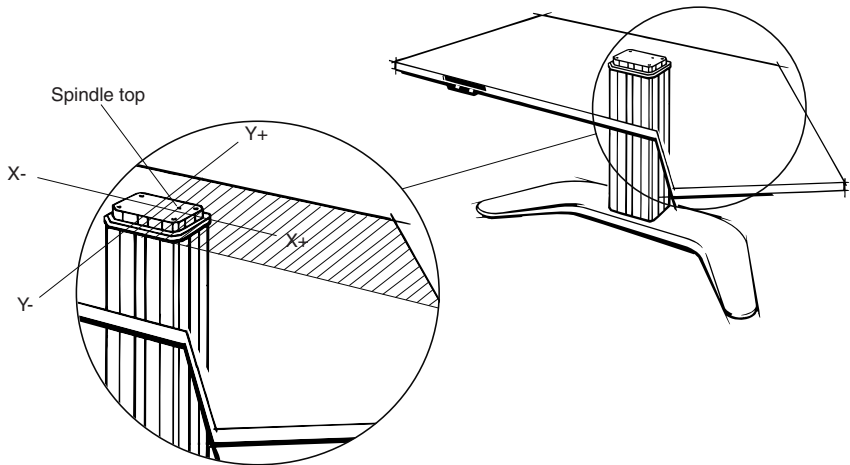

Figure 2

To limit the influence from the bending moment it is recommended to place the heaviest load in the shaded area (see figure 2) in which the spindle is placed. The spindle part is placed in the same side as the cable outlet. See the DL2 data sheet for further information regarding bending moment.



LINAK recommends that the DESKLINE® system should be used in push applications.

Mounting guidelines CBD2N

The control box is to be fastened with 4 screws with a head diameter between $\varnothing 8$ and $\varnothing 10$ mm. Out of regard for the tension surface $\varnothing 10$ mm is preferable.

See drawing appendix for placing of mounting holes and the space the CBD takes up.

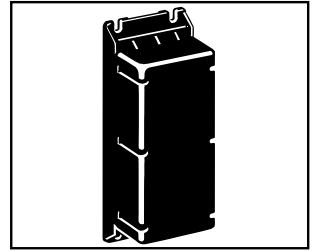

CBD2N - Control box

The CBD must not be packed in heat insulating material, but must be placed so that it can emit waste heat into the surroundings. There are no ventilation holes to consider, the CBD emits heat through the surface.

The plug must be visible when the CBD is mounted so that the supply to the CBD can be disconnected at replacement, if any.

The mounting screws on the control box must be fastened with a max. torque of 1 Nm.

The mounting surface, to which the control box is attached, should have a surface evenness of max. ± 0.5 mm.

For mounting and operation of the desk panel, please see the separate user manual for desk panels.

Electrical connection of the DL2 system:

DESKLINE system with a CBD2N which is not built into the DL2:

The DESKLINE® system is to be connected as shown on figure 3. *The DL2 is to be connected to the socket on the control box by means of the motor cable, which is supplied with an 8-pin plug.* The connection of the DL2's are on the same side of the control box.

See figure 3.



Be careful that the plugs are fixed exactly above the counterpart before pushing them together. Otherwise the plugs may bend and following errors may occur:

- The lifting units will not run as there is no current
- The lifting units cannot find the end-stop positions

In the worst case the switches in the control box will short-circuit, which will damage the CBD2.

The control (DP) is to be connected to port B on the control box - the opposite side of the DL2 column (see figure 3).

The connection is made by a 8 pole modular jack plug.

Up to 2 SLS (Safety Limit Switches) can be connected to the control box on the opposite side of the lifting units. The connection is made by DC mini jack plugs (see figure 3).

Finally the mains cable is to be mounted and power switched on.



Please note that the control box must only be connected to the voltage stated on the label.

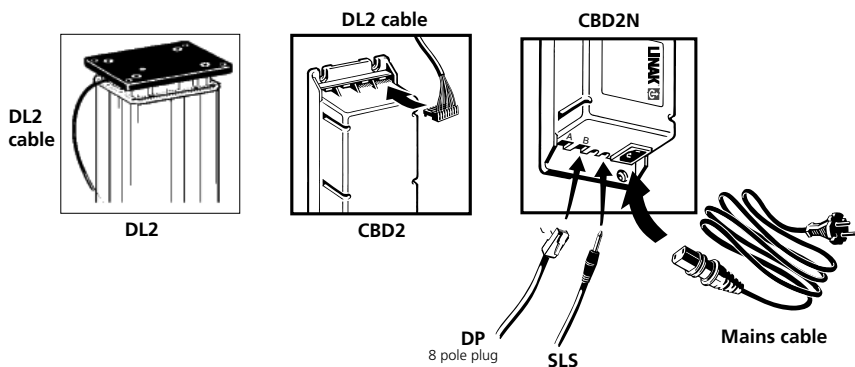

Figure 3

DESKLINE system with a built-in CBD2:

The DESKLINE® system is to be connected as shown on figure 15. *The lifting unit DL2 is equipped with an 8 pole female modular jack for connection of the control. The DL2 is also equipped with a fixed mains cable.*

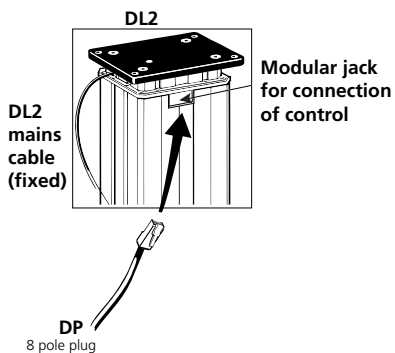
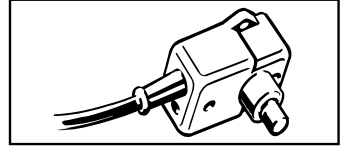

Figure 4

Operation with SLS

The CBD2N supports two SLS (Safety Limit Switch) inputs. The switches must be type NO (normally open). The SLS can optionally be connected to the SLS input. Each SLS input controls one function. The function is stated by choice of CBD2N. Below functions are possible:

- 1 input, CH1 down
- 2 input, CH1 and CH2 down
- 1 input, CH1 up
- 2 input, CH1 and CH2 up
- 2 input, CH1 up and down
- 2 input, CH1 down and CH2 up



SLS (Safety Limit Switch)

When SLS is activated the movement will stop immediately. It will not be possible to drive in the opposite direction until reactivating the control.

Description of the DESKLINE® DL2 Memory System with CBD2 E/F/G

The DESKLINE® DL2 Memory system contains the following products:

- 1, 2 or 3 DL2 lifting column (s)
- 1 Control box CBD2
- 1 DP Desk Panel
1 DPA/DPB Desk Panel
- 1 Exchangeable mains cable
(With mains cut-off the cable is not exchangeable)

Options:

- Built-in control box (CBD)
- Class 1 protection (not if built-in CBD)
- Prepared for 1 or 2 anti-squeeze safety switches
(NO type = normally open), only stop (not if built-in CBD)
- It is possible to run extra actuators (LA31 with hall) (not if built-in CBD)

Description of the DESKLINE® DL2 system

Each Deskline lifting unit DL2 is equipped with a motor and memory drive is ensured by means of software in the CBD2. CBD2 also has soft start, which ensures a soft start when adjusting the desk.

Application of the DESKLINE® DL2 system:

Irrespective of the load the **duty cycle 5% ~ 3 min./ hour or max. 1 min. at continuous use** stated in the data sheets, must **NOT** be exceeded as this will result in a overheating of the motor, the brake and the spindle nut. Exceeding the duty cycle will result in a dramatic reduction of the life of the system.

Mounting guidelines for DL2 System

The DL2 column is supplied with either 8 mm end plates or 3 mm end plates.

8 mm end plates:

For mounting on the desk frame there are 4 holes for M10 bolts. It is recommended to use all 4 bolts.

3 mm end plates:

For mounting on the desk frame there are 4 holes in the column for DG 80 x 35 screws. It is recommended to use all 4 screws.

As the table top amplifies the sound we advise you to place a vibration/shock-absorbing material between the table top and the table frame.

The outer profile of the DL2 column has tracks, which can be used for mounting a bracket. The mounting bracket can be used for e.g.:

- Mounting the control box.
- Mounting an extra actuator for tilt function of the table top.
- Mounting of a computer hard disc

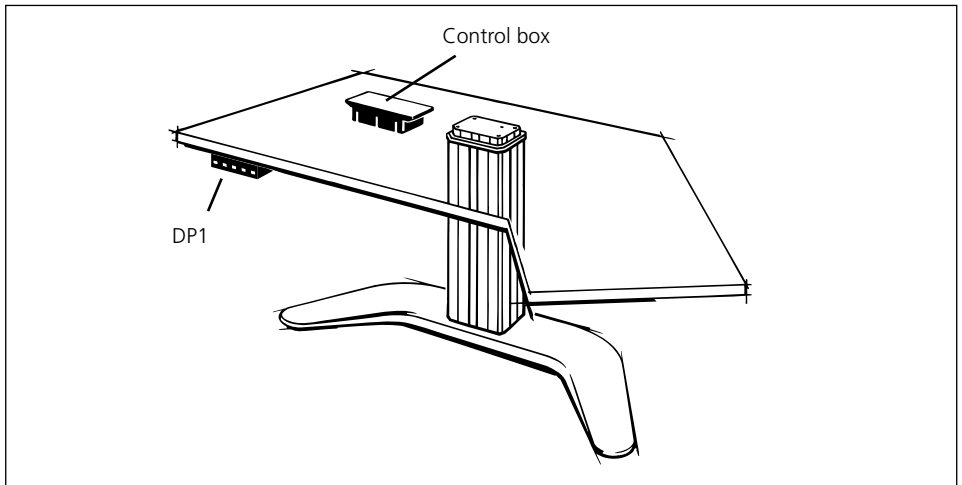

Figure 5
Example of how to mount a DL2 system

Bending moment

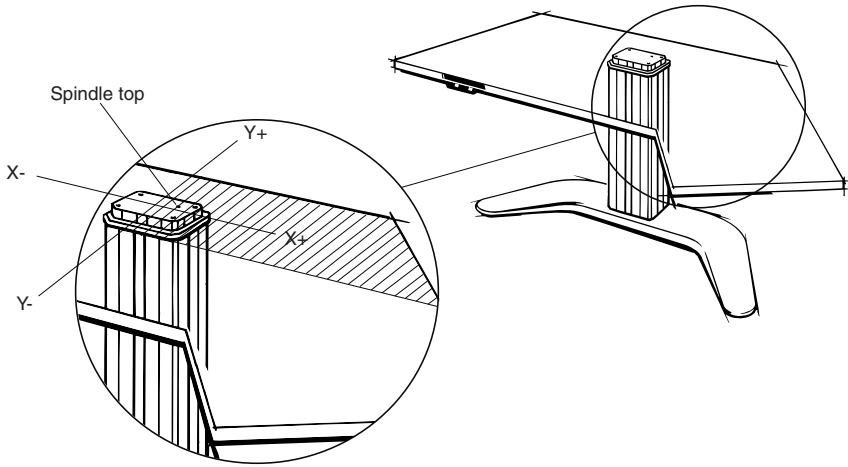

Figure 6

To limit the influence from the bending moment it is recommended to place the heaviest load in the shaded area (see figure 6) in which the spindle is placed. The spindle part is placed in the same side as the cable outlet. See data sheet for DL2 for further information regarding bending moment.



LINAK recommends that the DESKLINE® system should be used in push applications.

Mounting guidelines CBD2 E/F/G

The control box is to be fastened with 4 screws with a head diameter between $\varnothing 8$ and $\varnothing 10$ mm. Out of regard for the tension surface $\varnothing 10$ mm is preferable. See drawing appendix for placing of mounting holes and the space the CBD takes up.

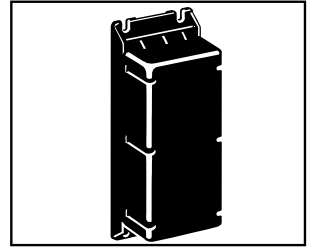

CBD2 - Control box

The CBD must not be packed in heat insulating material, but must be placed so that it can emit waste heat into the surroundings. There are no ventilation holes to consider, the CBD emits heat through the surface.

The plug must be visible when the CBD is mounted so that the supply to the CBD can be disconnected at replacement, if any.

The mounting screws on the control box must be fastened with a max. torque of 1 Nm.

The mounting surface, to which the control box is attached, should have a surface evenness of max. ± 0.5 mm.

Electrical connection of the DL2 system:

DESKLINE system with a CBD which is not built into the DL2:

The DESKLINE® system is to be connected as shown on figure 10 and 11. *The DL2 is to be connected to the socket on the control box by means of the motor cable, which is supplied with an 8-pin plug.* The connection of the DL2's are on the same side of the control box. See figure 10.



Be careful that the plugs are fixed exactly above the counterpart before pushing them together. Otherwise the plugs may bend and following errors may occur:

- The lifting units will not run as there is no current
- The lifting units start to run but stop due to lack of pulses
- The lifting units cannot find the end-stop positions
- The system cannot be initialised and therefore it cannot find its memory positions.

In the worst case the switches in the control box will short-circuit, which will damage the CBD2 (see figure 10).

The control (DP/DPA/DPB) is to be connected to port B on the control box - the opposite side of the DL2 column (see figure 10). The connection is made by means of a 6 or 8 pole modular jack plug. Up to 2 SLS (Safety Limit Switches) can be connected to the control box on the opposite site of the lifting units. The connection is made by means of DC mini jack plugs (see figure 10).

Finally the mains cable is to be mounted and power switched on.



Please note that the control box must only be connected to the voltage stated on the label.

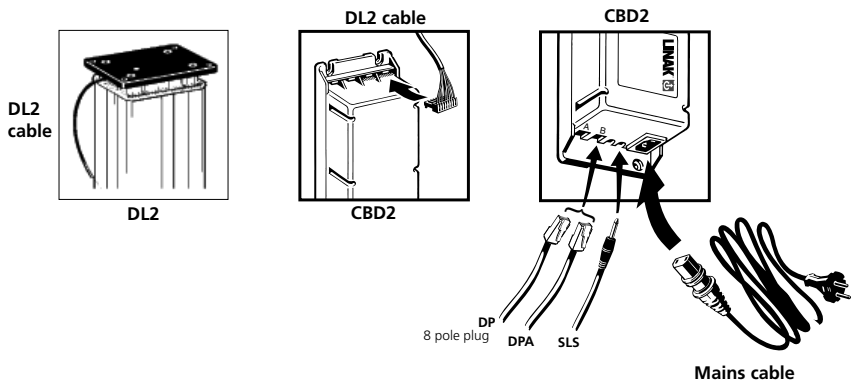

Figure 10

DESKLINE system with a built-in CBD2:

The DESKLINE® system is to be connected as shown on figure 11. *The lifting unit DL2 is equipped with a 8 pole female modular jack for connection of the control. The DL2 is also equipped with a fixed mains cable.*

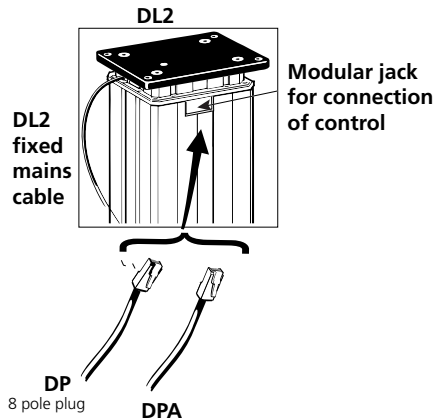

Figure 11

Initialisation of the DESKLINE® DL2 system

To obtain memory operation of a DESKLINE system it is necessary that the system drives the lifting columns DL2 in end-stop position bottom at first activation. Thus the control box CBD2 registers the bottom position for each lifting column.

If an extra actuator apart from the DL2 is connected to the system this actuator must also be initialised. Drive the actuator to inner position and then to outer position.

Besides the system has to be initialised when exchanging the lifting columns or the control box.

Operation with SLS (DL2 system)

The software supports two SLS (Safety Limit Switch) inputs. The switches must be NO (Normally Open) types. The SLS can optionally be connected to the SLS inputs.

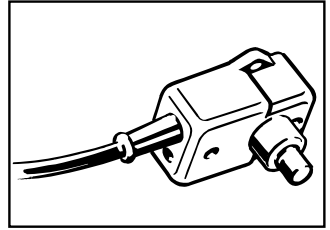

SLS (Safety Limit Switch)

Each SLS input controls one function according to the table below (stated when ordering the CBD). If the SLS is activated while a channel move downwards the movement will stop immediately whereafter the channel automatically will move approx. 10 mm upwards and stop. It will only be possible to initiate movement in the upward direction as long as the SLS is active. When the SLS is released again and all keys on the Handheld Control have been released the Control Box will allow movement in both directions.

During a Memory drive session activating the SLS will stop the active channel irrespective of the direction. If the channel was moving downwards at the time the SLS was activated this channel will automatically move approx. 10 mm upwards and stop. The Memory drive session is abandoned.

SLS input	Channel 1	Channel 2	Channel 3
1	Stop	Stop	
2			Stop

Disposal of LINAK's products

As LINAK's customers often ask us how our products can be disposed of or scrapped we have prepared this guidance that enables a classification to different waste fractions for recycling or combustion.

Guidance

We recommend that our products be disassembled as much as possible and divided into different waste groups for recycling or combustion.

For example, waste can be sorted into metals, plastics, cable scrap, combustible material, and recoverable resources.

Some of these main groups can be further divided into subgroups; e.g. metal can be divided into steel/aluminium/copper and plastic can be divided into ABS/PA/PE/PP.

As an example, the table below breaks down the different components in LINAK products to various recycling groups:

Product	Components	Recycling group
Columns/ Actuator :	Spindle and motor Plastic housing Cable PCB boards	Scrap Plastic recycling or combustion Cable scrap or combustion Electronics scrap
Control Box:	PCB boards Plastic housing Cable Transformer	Electronics scrap Plastic recycling or combustion Cable scrap or combustion Metal scrap
Handset/Control:	Plastic housing Cable PCB board	Plastic recycling or combustion Cable scrap or combustion Electronics scrap

By now almost all our casted plastic parts are supplied with an interior code for plastic type and fibre contents, if any.

Main groups of disposal

Product main groups	Metal Scrap	Cable scrap	Electronics scrap	Plastic recycling or combustin	Comments
DL2	X	X	X	X	
CBD2	X		X	X	
DPXX		X	X	X	
SLS		X	X	X	

Label for CBD2

LINAK® 
WE IMPROVE YOUR LIFE

Item : CBD2E000100-39
Date : 2006.05.09
U In : 230 V ~, 50 Hz
P In : 400 W
U Out: 24 V ~
Op. : 5 %, Max. 1 min./19 min.
S.W. P/N.: 0077100 Ver. 1.10



NOT TO BE OPENED BY UNAUTHORIZED PERSONNEL 

P.O.123456 - 0000 MADE BY LINAK A/S DENMARK



Label for DL2

LINAK® 
WE IMPROVE YOUR LIFE

Item No. : DL2400A00500655
Prod. Date : 2006.05.09
Max Load : 1000 N
Power Rate: 24 V ~ / Max 7 Amp.
Duty Cycle : 5 %, Max. 1 min./19 min.
NOT TO BE OPENED BY UNAUTHORIZED PERSONNEL 



P.O.123456 - 0001 MADE BY LINAK A/S DENMARK



DRAWING APPENDIX

DESKLINE® DL2 System:

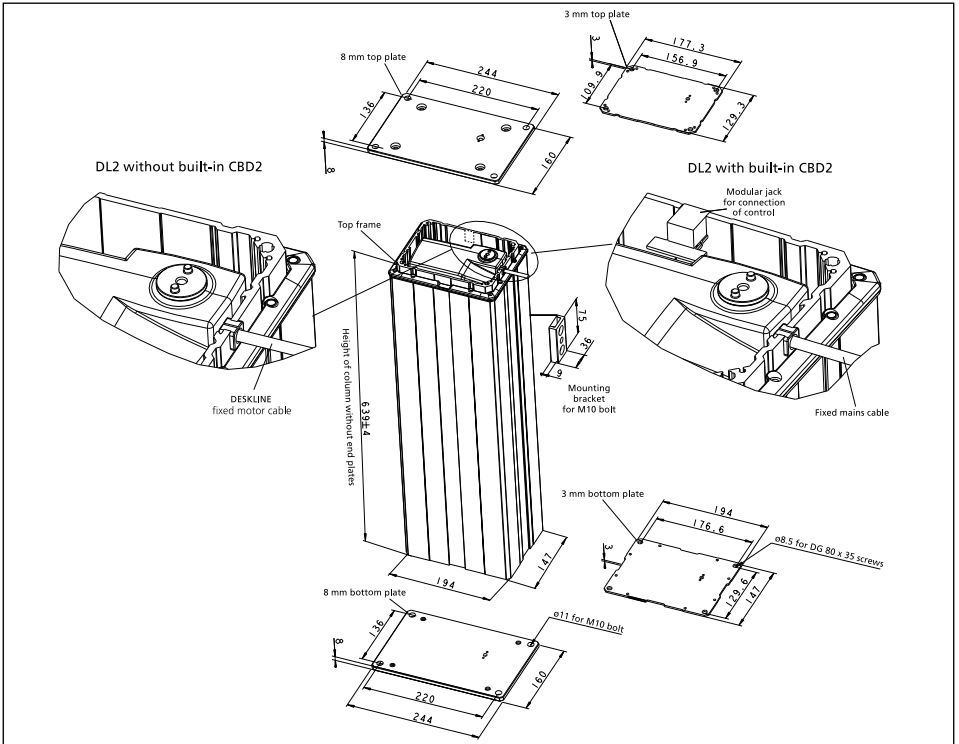
DL2 Lifting Column



CBD2 Control Box

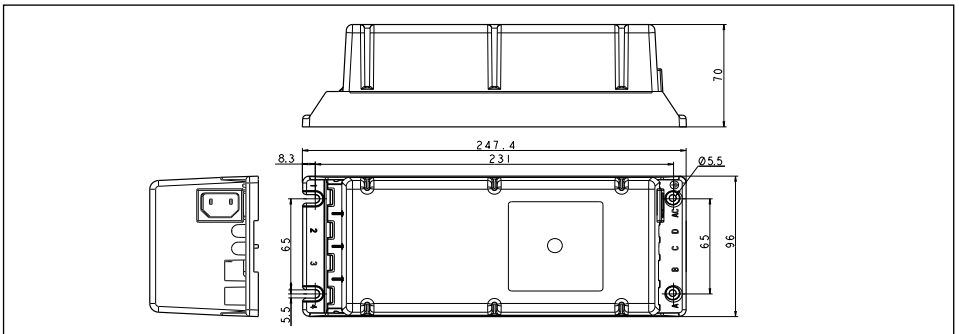

DECLARATION OF CONFORMITY

LINAK A/S
Smedevænget 8
DK - 6430 Nordborg

hereby declares that LINAK Actuator System composed of:

Control Box:
CBD2xxxxxxx-xx

Desklift(s):
DL2xxxxxxxxxxx,
optional: Linear Actuator 31xxxxxxxxxxxx

Desk Panel/Display Panel/Foot Switch:
DPxxx-xxxxxx,

complies with the EMC-directive 89/336/EØF according to the standards EN61000-6-1:2001,
EN61000-6-3:2001

and complies with Low Voltage Directive 73/23/EØF according to the standard
EN60335-1:1994, A1:1996, A12:1996, A13:1998, A14:1998

Machinery Directive 98/37/EC Attachment IIB: LINAK A/S prohibit that the actuator system is
put into service until the machinery into which the actuator system is to be incorporated has
been declared in conformity with the provisions of all relevant directives

Date: 2004-08-02

Signature:



(Hans Schou Christensen)

FACTORIES

CHINA

LINAK (Shenzhen) Actuator Systems, Ltd.
Phone: +86 755 8610 6656
Fax: +86 755 8610 6990
E-mail: sales@linak.cn
www.linak.cn

DENMARK

LINAK A/S - Group Headquarters, Gudenup
Phone: +45 73 15 15 15
Fax: +45 74 45 80 48
Fax: +45 73 15 16 13 (Sales)
E-mail: info@linak.com
www.linak.com

SLOVAKIA

LINAK Slovakia s.r.o.
Phone: +421 51 75 63 414
Fax: +421 51 75 63 410
E-mail: jp@linak.sk
www.linak.com

USA

LINAK U.S. Inc. North and South American Headquarters
Phone: +1 502 253 5595
Fax: +1 502 253 5596
E-mail: info@linak-us.com
www.linak-us.com

SUBSIDIARIES

AUSTRALIA

LINAK Australia Pty. Ltd
Phone: +61 3 8796 9777
Fax: +61 3 8796 9778
E-mail: sales@linak.com.au
www.linak.com.au

AUSTRIA

LINAK Repräsentanz Österreich (Wien)
Phone: +43 (1) 890 7446
Fax: +43 (1) 890 744615
E-mail: info@linak.de
www.linak.at

BELGIUM & LUXEMBOURG

LINAK Actuator-Systems NV/SA
Phone: +32 (0)9 230 01 09
Fax: +32 (0)9 230 88 80
E-mail: info@linak.be
www.linak.be

BRAZIL

LINAK Do Brasil Comércio De Atuadores Ltda.
Phone: +55 (11) 2832 - 7070
Fax: +55 (11) 2832 - 7060
E-mail: info@linak.com.br
www.linak.com.br

CANADA

LINAK Canada Inc.
Phone: +1 502 253 5595
Fax: +1 416-255-7720
E-mail: info@linak.ca
www.linak.us.com

CZECH REPUBLIC

LINAK C&S S.R.O.
Phone: +420581741814
Fax: +420581702452
E-mail: ponizil@linak.cz
www.linak.cz

DENMARK

LINAK Denmark A/S
Phone: +45 86 80 36 11
Fax: +45 86 82 90 51
E-mail: linak@linak-silkeborg.dk
www.linak.dk

FINLAND

LINAK OY
Phone: +358 10 841 8700
Fax: +358 10 841 8729
E-mail: linak@linak.fi
www.linak.fi

FRANCE

LINAK France E.U.R.L.
Phone: +33 (0) 2 41 36 34 34
Fax: +33 (0) 2 41 36 35 00
E-mail: linak@linak.fr
www.linak.fr

GERMANY

LINAK GmbH
Phone: +49 6043 9655 0
Fax: +49 6043 9655 60
E-mail: info@linak.de
www.linak.de

INDIA

LINAK A/S India Liaison Office
Phone: +91 120 4393335
Fax: +91 120 4273708
E-mail: info@linak.in
www.linak.in

IRELAND

LINAK UK Limited - Ireland
Phone: +44 (0)121 544 2211
Fax: +44 (0)121 544 2552
+44 (0)796 855 1606 (UK Mobile)
+35 387 634 6554 (Republic Of Ireland Mobile)
E-mail: sales@linak.co.uk
www.linak.co.uk

ITALY

LINAK Italia S.r.l.
Phone: +39 02 48 46 33 66
Fax: +39 02 48 46 82 52
E-mail: info@linak.it
www.linak.it

JAPAN

LINAK K.K.
Phone: 81-45-533-0802
Fax: 81-45-533-0803
E-mail: linak@linak.jp
www.linak.jp

MALAYSIA

LINAK Actuators Sdn. Bhd.
Phone: +60 4 210 6500
Fax: +60 4 226 8901
E-mail: info@linak-asia.com
www.linak.my

NETHERLANDS

LINAK Actuator-Systems B.V.
Phone: +31 76 5 42 44 40
Fax: +31 76 5 42 61 10
E-mail: info@linak.nl
www.linak.nl

NEW ZEALAND

LINAK New Zealand Ltd.
Phone: +64 9580 2071
Fax: +64 9580 2072
E-mail: nzsales@linak.com.au
www.linak.co.nz

NORWAY

LINAK Norge AS
Phone: +47 32 82 90 90
Fax: +47 32 82 90 98
E-mail: info@linak.no
www.linak.no

POLAND

LINAK Polska
Phone: +48 (22) 500 28 74
Fax: +48 (22) 500 28 75
E-mail: dkreh@linak.dk
www.linak.pl

REPUBLIC OF KOREA

LINAK Korea Ltd.
Phone: +82-(0)2-6231-1515
Fax: +82-(0)2-6231-1516
E-mail: scully@linak.kr
www.linak.kr

RUSSIAN FEDERATION

000 LINAK
Phone: +7 495 280 14 26
Fax: +7 495 687 14 26
E-mail: info@linak.ru
www.linak.ru

SPAIN

LINAK Actuadores, S.L.u
Phone: +34 93 588 27 77
Fax: +34 93 588 27 85
E-mail: linakact@linak.es
www.linak.es

SWEDEN

LINAK Scandinavia AB
Phone: +46 8 732 20 00
Fax: +46 8 732 20 50
E-mail: info@linak.se
www.linak.se

SWITZERLAND

LINAK AG
Phone: +41 43 388 31 88
Fax: +41 43 388 31 87
E-mail: info@linak.ch
www.linak.ch

TAIWAN

LINAK A/S Taiwan Representative Office
Phone: +886 2 27290068
Fax: +886 2 27290096
Mobile: +886 989292100
E-mail: michael.chen@linak.com.tw
www.linak.com.tw

TURKEY

LINAK İth. İhr. San. ve Tic. A.Ş.
Phone: +90 312 4726338
Fax: +90 312 4726635
E-mail: info@linak.com.tr
www.linak.com.tr

UNITED KINGDOM

LINAK UK Limited
Phone: +44 (0)121 544 2211
Fax: +44 (0)121 544 2552
E-mail: sales@linak.co.uk
www.linak.co.uk

DISTRIBUTORS

ARGENTINA

Novotec Argentina SRL
Phone: +[54] (11) 4303-8900
+ [54] (11) 4303-8989
Fax: + [54] (11) 4032-0184
E-mail: info@novotecargentina.com
www.novotecargentina.com

AUSTRALIA

Ballarant Industrial Supplies
www.ballind.com.au
BL Shipways & Co
www.blshipway.com.au

Gas Strut Marine and Industrial
www.gasstrutmarine.com.au

Prime Motion & Control
www.primemhd.com.au

West Vic Industrial Supplies
www.westvicindustrial.com.au

COLOMBIA

MEM Ltda
Phone: +[57] (1) 334-7666
+ [57] (1) 282-1684
E-mail: servicioalcliente@memtltda.com
www.memtltda.com

INDONESIA

PL, Himalaya Everest, Jaya
Phone: +6 221 544 8956,
+6 221 544 8965,
+6 221 619 4658,
+6 221 619 1925
E-mail: hejplastic-div@centrin.net.id
www.hej.co.id

IRAN

Bod Inc.
Phone: +98 2188998635 - 6
Fax: +98 2188954481
E-mail: info@bod.ir
www.bod.ir

MEXICO

ILSA S.A. de C.V.
Phone: +[52] (55) 5388-3960
+ [52] (55) 5388-3966
E-mail: linak@ilsamexico.com
www.ilsamexico.com

PERU

Percy Martin Del Aguila Ulbilus
Phone: +51 99- 883-9879

RUSSIAN FEDERATION

000 FAM
Phone: +7 812 3319333
Fax: +7 812 3271454
E-mail: purchase@fam-drive.ru
www.fam-drive.ru

SINGAPORE

Servo Dynamics Pte. Ltd.
Phone: +65 6844 0288
Fax: +65 6844 0070
E-mail: servodynamics@servo.com.sg
www.servo.com.sg

SOUTH AFRICA

Industrial Specialised Applications CC
Phone: +27 11 312 2292 or
+27 11 2077600 (Switch Board)
Fax: +27 11 315 6999
E-mail: gartht@isagroup.co.za
www.isaza.co.za

UNITED ARAB EMIRATES

Mechatronics
Phone: +971 4 267 4311
Fax: +971 4 267 4312
E-mail: mechtron@emirates.net.ae
www.mechtronics.ae

For contact details on other countries please visit www.linak.com or contact:

LINAK INTERNATIONAL

Phone: +45 73 15 15 15
Fax: +45 74 45 90 10
Fax: +45 73 15 16 13 (Sales)
E-mail: Terms_of_use@linak.com

Linak is responsible for determining the suitability of LINAK products for specific application. LINAK takes great care in providing accurate and up-to-date information on its products. However, due to continuous development in order to improve its products, LINAK products are subject to frequent modifications and changes without prior notice. Therefore, LINAK cannot guarantee the correct and actual status of said information on its products. While LINAK uses its best efforts to fulfil orders, LINAK cannot, for the same reasons as mentioned above, guarantee the availability of any particular product. Therefore, LINAK reserves the right to discontinue the sale of any product displayed on its website or listed in its catalogues or other written material drawn up by LINAK. All sales are subject to the Standard Terms of Sale and Delivery for LINAK. For a copy hereof, please contact LINAK.



WE IMPROVE YOUR LIFE